



# USER MANUAL



**IMPORTANT: This manual should be reviewed completely BEFORE the User (or anyone operating the device) begins to use it.**



## IMPORTANT: START HERE – READ THIS PAGE!

### Supplier:

- This manual **MUST** be given to the user of the AMP device.

### User:

- This manual should be reviewed completely **BEFORE** you (or anyone else operating the AMP device) begins using it.
- You should follow all instructions and make sure you understand them.
- If you don't understand something, please ask your Authorized Method Mobility Supplier to explain it to you.
- Do not use the AMP device if you still have any questions.
- Please save this manual so you can check it for information if you have a question in the future.
- This manual only has information about the AMP power assist or add-on device.
- This manual is **NOT** a replacement for your wheelchair user manual.
- The user manual for your wheelchair should **ALWAYS** be where you look for information about adjustments,

maintenance, safety checks, troubleshooting, etc. for your wheelchair.

- **CAUTION:** Federal law restricts this device to sale by or on the order of a practitioner licensed by the law of the State in which he/she practices.

### Supplier and User:

- You will see “**WARNINGS**” throughout this manual. Warnings will look like this:

## **WARNING**

- Warnings are hazards or unsafe ways to use the AMP device that **MAY CAUSE SEVERE INJURY OR EVEN DEATH** to the user or another person.
- **READ ALL WARNINGS AND MAKE SURE YOU UNDERSTAND THEM!**
- **DO NOT** use the AMP device until you are sure you understand how to avoid these hazards and unsafe ways to use it.
- When adding the AMP Power Module to your existing Manual wheelchair you must continue to maneuver the complete unit as the Manual chair is intended to be used. The AMP does not change the intended use of the Manual chair. It is intended to assist.



## REGISTER YOUR PRODUCT

At Method Mobility, we take pride in providing the best products available to help your mobility and get you where you want to go! Thank you for choosing us and taking us along on your journey! Please be sure to register your product so you can receive any necessary warranty services and we can update you with any needed product information.

Warranty Registration: [www.methodmobility.com/registration](http://www.methodmobility.com/registration)

### You will need:

AMP Serial Number: \_\_\_\_\_

*(AMP Serial Numbers are located underneath the AMP base.)*

Purchase Date: \_\_\_\_\_

Your Contact Information *(Address, email, etc.)*

*(If you prefer not to register your product on our website, you can also send this information to our Customer Care Department at the mailing address below.)*



---

### METHOD MOBILITY CONTACT INFORMATION

If you have questions or comments about your device, this user manual, your supplier or anything else you'd like us to know, please feel free to contact us:



**Customer Care Department**

2562 N. Fordham Avenue

Fresno, CA 93727 USA

Telephone: (888) 88AMP88 (882-6788)

Email: [CustomerCare@methodmobility.com](mailto:CustomerCare@methodmobility.com)

---

### SUPPLIER INFORMATION

Your Authorized Method Mobility Supplier knows you and your mobility products firsthand. They should be able to answer your mobility product questions and help with any maintenance, adjustments and more. Keep track of your Method Mobility Supplier information here:

Supplier Name: \_\_\_\_\_

Name(s) of People You Worked With: \_\_\_\_\_

Supplier Address: \_\_\_\_\_

Telephone Number: \_\_\_\_\_ Mobile Number: \_\_\_\_\_

Email Address(es): \_\_\_\_\_



# TABLE OF CONTENTS

<b>1. INTRODUCTION .....</b>	<b>1</b>	<b>4. BATTERY INFORMATION AND WARNINGS .....</b>	<b>15</b>
1.1 Intended Use .....	1	4.1 Battery Operated .....	15
1.2 Your Product and Components .....	1	4.2 Battery Type .....	15
1.3 Joystick Components (Optional) .....	2	4.3 Characteristics and Handling of the Lithium Iron Phosphate Battery (LiFePO4) .....	16
<b>2. ELECTROMAGNETIC INTERFERENCE (EMI) INFORMATION AND WARNINGS .....</b>	<b>5</b>	4.4 Charging Your AMP Battery .....	16
2.1 What is EMI? .....	5	4.5 Battery Storage .....	18
2.2 What Effect Can EMI Have? .....	5	4.6 Charger Indicator Lights .....	19
2.3 Sources of EMI .....	5	4.7 Battery Levels and Safety .....	19
2.4 Distance from the Source .....	7	4.8 Checking Battery and Charger .....	20
2.5 Immunity Level .....	7	4.9 Battery Wiring Diagram .....	21
2.6 Contact Method Mobility About Suspected EMI Incidents .....	7	4.10 Safe Disposal Of Lithium-Ion Phosphate Batteries .....	22
<b>3. GENERAL INFORMATION AND WARNINGS .....</b>	<b>9</b>	<b>5. MAINTENANCE INFORMATION AND WARNINGS .....</b>	<b>23</b>
3.1 Know your Device .....	9	5.1 Introduction .....	23
3.2 Weight Limit .....	9	5.2 Maintenance and Cleaning .....	23
3.3 Device Intended Use .....	9	5.3 Important Safety Checklist .....	23
3.4 Attendants and Caregivers .....	9	5.4 Troubleshooting .....	24
3.5 Safety Check .....	9	5.5 Use and Set Up .....	25
3.6 Modifications and Accessories .....	10	5.6 Joystick Set Up and Use .....	25
3.7 Changes and Adjustments .....	10	5.7 General Joystick Information .....	26
3.8. Power On/Off .....	10	5.8 Joystick Use .....	27
3.9 Anti-Tip .....	11	5.9 Getting Ready to Drive .....	28
3.10 Center of Balance .....	11	5.10 Driving – General .....	28
3.11 Environmental Conditions .....	12	5.11 Driving Technique .....	29
3.12 Use and Skill Development .....	12	5.12 Hazards/ Warnings .....	29
3.13 Transit .....	12	5.13 Joystick Knobs .....	30
3.14 Lifts .....	12	5.14 Storage .....	30
3.15 Airline Travel .....	13	5.15 Freewheel Mode .....	31
3.16 Fasteners and Hardware .....	13	<b>6. AUTHORIZED METHOD MOBILITY SUPPLIER SERVICE AND ADJUSTMENT .....</b>	<b>33</b>
		6.1 Service and Adjustment .....	33
		<b>7. LIMITED LIFETIME WARRANTY .....</b>	<b>35</b>
		7.1 Warranty Details .....	35
		7.2 Service Record .....	35





## SECTION 1 - INTRODUCTION

This manual only has information about the AMP power assist or add-on device. This manual is NOT a replacement for your wheelchair user manual. The user manual for your wheelchair should ALWAYS be where you look for information about adjustments, maintenance, safety checks, troubleshooting, etc. for your wheelchair.

### 1.1 Intended Use

The AMP by Method Mobility is intended to provide enhanced mobility to disabled persons who are capable of operating a powered and manual wheelchair by providing powered mobility to manual wheelchairs.

### 1.2 Your Product and Its Components (Parts)



**Figure A: List of Components (Parts):**

- a. Outrigger for Wheelchair Wheel
- b. 8" Drive Wheelmotor
- c. Anti-Tip Bumper
- d. Release Lever
- e. Front Caster
- f. Joystick Plug-In Location
- g. Shroud

#### Available Accessories Include:

- Joystick Handles, Standard, T-Handle and Knob Handle
- Armrest Swing Away Mount
- Attendant Mount Joystick
- Back Up Battery
- Spare Battery Charger

**NOTE:** For the most current list of accessories always refer to your order form.



**Figure B:**  
Example of Wheelchair  
Docked on an AMP  
Power Module

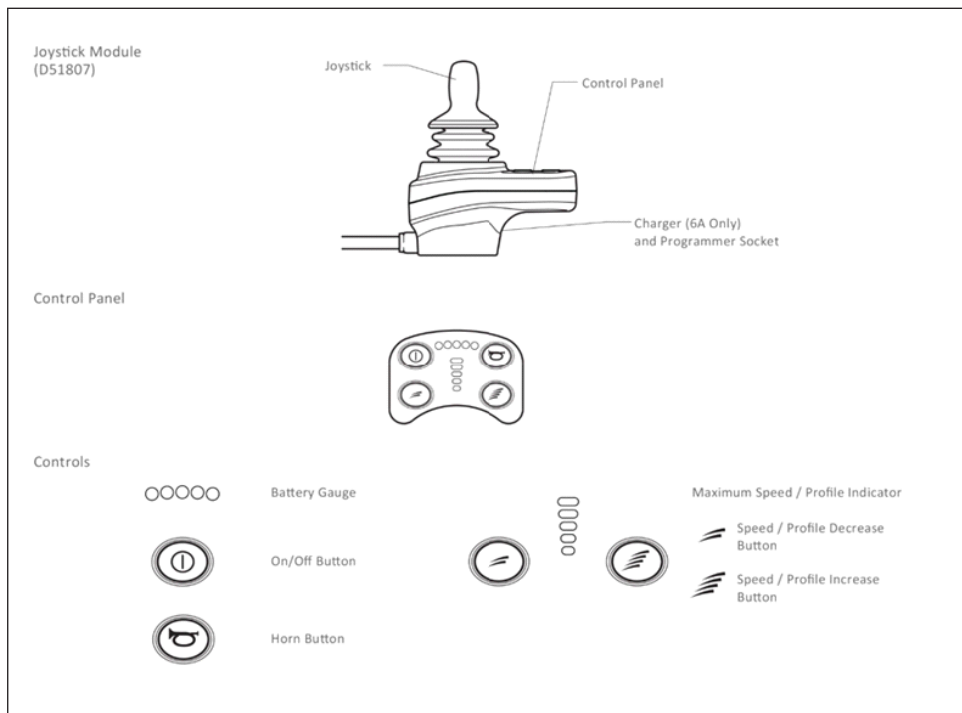

**Figure C:**  
Joystick Controller  
Mounted to Wheelchair

### 1.3 Joystick Components (Optional)



**Figure D:**  
Joystick



**Figure E:** Joystick Diagram

**NOTE:** AMP is designed to be used with a manual wheelchair including folding wheelchairs, rigid wheelchairs and tilt wheelchairs. Although AMP works with most models of manual wheelchairs, there may be times when this is not the case.

Recommendations include:

- Greater than 5” in diameter caster wheels
- Rear wheel configurations of 24”, 25”, or 26”
- Some seat heights may cause interference with AMP Module; clearance from the rear frame to ground must not be less than 8.5”.

Consult your Authorized Method Mobility Supplier to determine if AMP is right for your wheelchair.



### **WARNING**

Make sure to follow all of these warnings to reduce the chance of unplanned brake release or wheelchair movement:

- Handheld transceivers (commonly known as walkie-talkies) can be dangerous near powered mobility devices like AMP. When your AMP is powered-up and turned on, DO NOT turn on or use a handheld transceiver. If a handheld transceiver is being used by someone near your AMP, be careful and stop or move away in a safe manner.
- Antennas that transmit radio waves (at radio stations or other types of radio communications) can cause interference. Avoid being near them.
- If something causes unplanned movement of your wheelchair, be careful and stop or move away in a safe manner. Turn off your AMP and undock as soon as you safely can.

#### 2.1 What Is EMI?

### **WARNING**

- EMI stands for: EM – electromagnetic and I - interference.
- Sources of EMI are radio waves that come from radio transmitters and transceivers. Transceivers are devices that send and receive radio waves – like a handheld two-way radio or walkie-talkie.
- There may be several sources of intense EMI found around you daily. Some sources are obvious and some less obvious. It may be difficult to avoid some sources of EMI.
- Powered mobility devices like AMP may be susceptible to EMI from radio stations, TV stations, amateur radio (ham) transmitters, two-way radios, radar systems or cellular phones and devices.
- EMI can also come from electrostatic discharge (ESD). ESD is commonly referred to as static electricity – when you touch something or someone that gives off a small shock of electricity. EMI also may come from “conducted” sources when it occurs where wires or cables connect a source and a receiver.

#### 2.2 What Effect Can EMI Have?

### **WARNING**

EMI can cause your wheelchair to suddenly:

- Release the brakes
- Move by itself
- Move in a direction you do not want it to
- If this happens, it could result in severe injury to you or others.

EMI can damage the control system of your AMP. This could be a safety hazard, and lead to expensive repairs.

#### 2.3 Sources of EMI

### **WARNING**

Sources of EMI fall into three general types:

- Handheld Transceivers or Radios: An antenna is attached to unit in most cases. Examples of handheld transceivers include:
  - Citizens Band (CB) radios
  - Walkie-Talkies

- First Responder Radios (Police, Fire, Security, etc.)
- Mobile Phones
- Laptop Computers (with phone or fax)
- Other Personal Communication Devices
- Electronic Article Surveillance Systems (Commonly used in retail stores to prevent theft by attaching tags to merchandise and sounding an alarm if the item is removed from the store.)
- RFID (Radio Frequency Identification) Readers or Emitters (Commonly used to scan various items such as price tags in retail stores, inventory codes in warehouses, ticket codes at events, etc.)
- Wireless accessories such as wheelchair controllers that use RF (Radio Frequency) transmitters.

**NOTE:** These types of devices can still transmit signals while they are turned on, even if they are not actively being used.

- **Medium-Range Mobile Transceivers:** An antenna is usually attached outside of a vehicle containing the device. Examples of medium-range mobile transceivers include:
  - Two-Way Radios used in Emergency Vehicles (Police Cars, Fire Trucks, Ambulances)
  - Two-Way Radios used in Taxi Cabs, Delivery Vehicles, Municipal Vehicles (like Garbage Trucks or Maintenance Equipment), etc.
- **Long-Range Transceivers:** Examples of long-range transceivers include:
  - Commercial Radio Station Antennas
  - Television Broadcast Tower Antennas
  - Amateur Radio
- **Medical devices that emit RF (Radio Frequency) signals may also be sources of EMI:**
  - X-Ray machines
  - CT scanners (Computerized Tomography)
  - Diathermy machines
  - MRI machines (Magnetic Resonance Imaging)

## **WARNING**

There is a significant risk of EMI by emissions from MRI machines. Powered wheelchairs and scooters, including AMP, should be prohibited from entering any MRI environment.

**NOTE:** These devices do not usually cause EMI problems:

- Laptop Computers (without phone or fax)
- Cordless Phones
- Televisions
- AM/FM Radios
- CD or Cassette Tape Players

## 2.4 Distance From the Source

### **WARNING**

Electromagnetic energy (EM) quickly becomes stronger the closer you get to its source. EMI from handheld devices can be a big problem because of this. A person using a handheld device can bring high levels of electromagnetic energy (EM) very close to your chair without you knowing it.

## 2.5 Immunity Level

### **WARNING**

- Electromagnetic energy (EM) is measured in volts per meter (V/m). AMP can resist EMI up to a certain level or “immunity level”.
- A high immunity level means less risk of EMI. A 20 V/m immunity level will protect AMP users from most EMI.
- AMP mounted to a wheelchair frame and using its standard batteries, has been tested to have at least a 20 V/m immunity level.

### **WARNING**

Adding accessories or modifying an AMP/wheelchair set-up can change the risk for EMI. Work with your Authorized Method Mobility Supplier to make sure these changes do not change your risk of an EMI incident.

## 2.6 Contact Method Mobility About Suspected EMI Incidents

### **WARNING**

If you have an unplanned brake release or wheelchair movement, be sure to contact Method Mobility. Make sure to let us know whether there was a potential EMI source near your wheelchair at the time.

Contact: Method Mobility Customer Care at (888) 882-6788 or [customercare@methodmobility.com](mailto:customercare@methodmobility.com).





## SECTION 3 - GENERAL INFORMATION AND WARNINGS

### 3.1 Know Your Device

#### **WARNING**

Be sure to get used to your AMP, its controls and how it works to build up your skills and confidence. Take your time and learn about how the controls feel, response time, speed and maneuvering. Using too much force or moving too quickly could cause your chair to tip over or you to lose control causing severe injury to you or others. Recognizing that any obstacle that encounters the front casters of any wheelchair can cause an abrupt impact/stop. By adding the AMP to your wheelchair, it does not improve obstacle clearance. Always understand your chair set up and limitations.

### 3.2 Weight Limit

#### **WARNING**

Your wheelchair and AMP each have specific maximum weight limits. These limits have been tested for safety. **DO NOT** go over weight limits specified by Method Mobility or your wheelchair manufacturer. If you do go over these weight limits, you may cause a fall, tip-over, loss of control, damage your AMP, damage your wheelchair and cause severe injury to you or others.

- **AMP Maximum Weight Limit: 265 lbs.** (Unless otherwise stated.)

Your Wheelchair Weight Limit: Check your wheelchair user manual for a weight limit. This weight limit should be for weight of the user and items carried/stored on the wheelchair.

**NOTE:** If your wheelchair has a weight limit of less than 265 lbs. make sure to stay under that specified weight limit. If your wheelchair weight limit is greater than the AMP weight limit, **DO NOT** exceed the AMP weight limit of 265 lbs.

### 3.3 Device Intended Use

#### **WARNING**

**DO NOT** use AMP for any purpose other than what it is intended. This could create a safety hazard, cause damage to your wheelchair and cause severe injury to you or others. Using AMP for unintended purposes will void the warranty.

### 3.4 Attendants and Caregivers

#### **WARNING**

Read all warnings and instructions in this user manual and make sure you understand them. Consult a healthcare professional if you have questions about how to safely assist a wheelchair user. They can help you with assistive method techniques suited to your abilities and experience.

#### **WARNING**

The AMP Module is not designed to support any individual standing on the back of the unit. If you fail to heed this warning you will seriously damage the AMP and could cause harm to the intended user of the AMP Power Module and will void all warranty of the product.

### 3.5 Safety Check

Each time you are going to use your AMP, make sure to do a safety check first. Be sure your wheelchair moves easily and everything works smoothly. Use the Safety Checklist and Troubleshooting Guide in this manual to help fix any problems with AMP. Always check the user manual for your wheelchair to find and fix any wheelchair-related problems. Your Authorized Method Mobility supplier can also help you find and correct any issues you may have.

**Safety Checklist:** See Section 5.3

**Troubleshooting Guide:** See Section 5.4

### 3.6 Modifications and Accessories

#### **WARNING**

Any modifications made to AMP and/or use of parts and accessories not supplied by or approved by Method Mobility may cause a safety hazard. Modifications and/or use of unauthorized parts or accessories may change the device's integrity and will void the warranty.

### 3.7 Changes and Adjustments

#### **WARNING**

Consult a healthcare professional and have them check basic fit and performance measurements and adjust seating components if needed.

When AMP is added to your existing wheelchair, adjustments to the wheelchair may be necessary. Method Mobility requires the wheelchair used with the AMP to ALWAYS be set up with a minimum ½" greater front seat height than rear seat height. To maintain the same seat angle when Docked on the AMP you can increase your Front seat height an additional ½" which will accommodate the rear seat height when Docked that adds ½" height. Always refer to your wheelchair manual for adjustments to the wheelchair.

It is recommended to use 5" or larger casters. Smaller casters will create situations where maneuvering over transitions is difficult.

### 3.8 Power On/Off

#### **WARNING**

When you want to power on (turn on) the AMP Power Module:

**AMP:** First, dock your wheelchair (Section 5.5) and make sure it is locked in place and secure the wheel locks from the manual wheelchair when using the joystick control. Next, power on your AMP (Figure F).

When you want to power off (turn off) the AMP Power Module (Figure G):

**To Undock:** First, turn power off (turn off) the power switch (Figure G); the brake will then lock. ALWAYS power off before undocking AMP from your wheelchair. Unsecure wheelchair wheel locks. Roll out of AMP.



**Figure F:**  
Power on.



**Figure G:**  
Power off.

### 3.9 Anti-Tip

## **WARNING**

AMP Power Module has an add-on Anti-Tip Bumper (Figure H) in the rear to avoid chair tip over. The bumper on the AMP power module to be utilized with your wheelchair anti-tip tubes. When driving with AMP, use extra care when you move your wheelchair backwards (in reverse). Your wheelchair is the most stable when you move forward.

- Move your wheelchair slowly and smoothly.
- Using your wheelchair's anti-tip tubes, make sure to turn them to their up position so they are not in the way or interfering with the AMP. In the up position the anti-tip tube will act in conjunction with the AMP anti-tip bumper as your Anti-tip device. (add picture) When the chair lifts in the front the tubes will contact the bumper and stop from tipping over. This is required for the Handrim driven option.
- When you are utilizing Joystick or attendant control, the wheellocks must be engaged to act as an anti-tip device.
- Always make sure the path you are moving in is clear.

If you do not follow this warning, you have a high risk of a fall, tip over or loss of control that can injury yourself or another person. You may also damage your wheelchair and the AMP.



**Figure H:** Anti-tip Bumper

### 3.10 Center of Balance

## **WARNING**

Adding the AMP to your existing wheelchair may affect your center of balance. Center of Balance is important because your wheelchair can become less stable and tip forward, back or to the side. The way your wheelchair is set up, any options and/or any changes you make may cause a risk of a fall or tip-over.

Method Mobility requires the wheelchair used with the AMP to ALWAYS be set up with a minimum ½” greater front seat height than rear seat height. To maintain the same seat angle when Docked on the AMP you can increase your Front seat height an additional ½” which will accommodate the rear seat height when Docked that adds ½” height.

- Center of Balance can also be affected by:
  - A change in your body position, posture, or weight distribution.
  - Using your wheelchair on a ramp or slope.
  - Weight from a backpack or other items added to chair or carried.
- To reduce risks of an accident from a center of balance change:
  - Have someone assist you until you know new center of balance points of your wheelchair and how to move safely. Consult a healthcare professional if you have questions about how to safely use the wheelchair with AMP.

If you do not follow this warning, you are at a high risk of a fall, tip over or lose control and cause severe injury to yourself or others.

### 3.11 Environmental Conditions

#### **WARNING**

- Avoid extreme cold and/or wet conditions whenever possible.
- Water or excess moisture that is allowed to collect can cause AMP to rust or corrode.
- Electronic components may also be affected.
- Never drive AMP into water or submerge the base.
- Parts are not watertight and may rust or corrode from the inside.
- When AMP comes into contact with water or moisture, dry your device as soon as you can.
- If you do not follow these warnings, damage to AMP and/or your wheelchair may occur, you could lose control and cause severe injury to yourself or others.
- The AMP is not intended to ride on surfaces not intended for the wheelchair or the wheelchair user's skills.
- The AMP is intended to be used on all ADA compliant surfaces.
- When using the AMP approach all thresholds and obstacles (never greater than 1") with caution. Do not attempt to go over any obstacle you are unsure of.

### 3.12 Use and Skill Development

- **Safety First.** As you maneuver your AMP through your daily activities, some may require practice to master specific skills. Always take the time with the product to become skilled in your own environment such as doorways, ramps, different terrains, elevators, etc.
- **Outdoors Surfaces.** AMP is designed for optimum stability under normal conditions such as level and dry solid surfaces. When possible, avoid soft or uneven surfaces. If unsure of any type of terrain it is always best to avoid it.
- **Curbs and Steps.** DO NOT ATTEMPT to conquer a threshold or curb great than 1" (one inch). Proceed with extreme caution. Always approach these obstacles straight forward. Any obstacles like this can cause a tip over and serious bodily harm. If ever in doubt, ask for assistance. Understand your skills. Failure to heed these guidelines can cause the product to tilt and cause injury to the operator. Approach a curb or obstacle slowly, and straight toward the obstacle. Increase your speed forward as you contact the obstacle and reduce speed as the rear wheels clear the obstacle.
- **Ramps.** When maneuvering up a ramp, curb or incline be sure to lean forward to allow your Center of Gravity to assist for maximum stability and safety. When maneuvering down a ramp, curb or incline slow your speed and sit back into the seat. NOTE: Do not drive down an incline in reverse.
- **Stairs and Escalators.** NEVER attempt these both up or down. ALWAYS use an elevator.

### 3.13 Transit

#### **WARNING**

AMP does not have a transit option. ALWAYS remove your wheelchair from the AMP base (undock) and use original equipment manufacturer (OEM) vehicle restraints when transport is necessary. If you do not follow this warning, damage to AMP and/or your wheelchair may occur and cause injury to yourself or others.

### 3.14 Lifts

If utilizing a vehicle lift to transport the AMP with the wheelchair refer to the vehicle Lift manual for operation.

### 3.15 Airline Travel

It is recommended when traveling with your AMP that you disconnect the battery cables. Be sure to check when traveling with the Airline as to the rules required to travel with batteries.



**Figure N:** Battery disconnected.

### 3.16 Fasteners And Hardware

#### **WARNING**

All fasteners and hardware used on the AMP Power Module have very specific sizes and strengths. NEVER replace genuine AMP fasteners and/or hardware with other off-the-shelf hardware. ONLY USE fasteners and hardware provided by an Authorized Method Mobility Supplier. If you do not follow this warning, damage to AMP and/or your wheelchair may occur and cause injury to yourself or others. Using fasteners and/or hardware not sourced from Method Mobility will void your warranty.



## SECTION 4 - BATTERY INFORMATION AND WARNINGS

### **WARNING**

You must read these safety warnings and instructions before using or charging your (“Battery”). Rechargeable Lithium Iron Phosphate polymer batteries are potentially hazardous and can present a serious FIRE HAZARD, SERIOUS INJURY and/or PROPERTY DAMAGE if damaged, defective or improperly used.

#### 4.1 Battery Operated

### **WARNING**

Batteries supply the power for your AMP. Like other batteries you may use, they do not have an unlimited amount of energy. They have limits on how long they can store and supply energy. A battery gradually deteriorates and capacity decreases over time with use. This is dependent on conditions of use and even when battery is not in use.

- You can charge batteries only a certain number of times before they will fail and no longer hold a charge. It is not necessary to refresh charge the batteries. The battery life is estimated to be 5 years with 1 charge/discharge cycle per day for 365 days per year. This is a total of 1825 cycles.
- When transporting your wheelchair and the AMP, ALWAYS power off the battery.
- When storing your AMP, disconnect the battery (Figure N). This will help preserve the life of the battery. (Also see Section 4.5)
- Only use AMP specified batteries. Check with your Method Mobility Authorized Supplier when it becomes necessary to change out a battery and purchase the same kind of battery that was originally supplied with your AMP.
- Before removing the battery:
  - Power off the AMP Power Module (Figure L).
  - Remove the shroud (Figure M) on the AMP Power Module
  - Disconnect battery connection and remove (Figure N).

### **WARNING**

Do not tamper, disassemble, or modify the battery in any way. Vibration, puncture, contact with metals, or tampering with the battery can cause it to fail.

### **WARNING**

In the event the battery leaks any fluid and gets onto your skin or into your eyes DO NOT RUB. Rinse well with water and immediately seek medical care. If left untreated, the battery fluid could cause damage to the eye and skin.

#### 4.2 Battery Type

The battery used to power the AMP system is a Lithium Iron Phosphate (LiFe PO<sub>4</sub>) battery and uses a plug in quick-connect charger.

- DO NOT use a charger other than the one provided with your AMP product from Method Mobility.
- This type of battery provides a higher energy capacity compared to the nickel metal hydride battery.
- The LiFe PO<sub>4</sub> is equipped with a Battery Management System (BMS). Known as a built-in microprocessor. This system uses a computer to track charge/discharge status, operating conditions, and temperature.
- The batteries are compact but high capacity. (25.7V x 12 Ah)

### 4.3 Characteristics and Handling of the Lithium Iron Phosphate Battery (LiFe P04)

- Ambient temperature. Depending on the ambient temperature, the distance that can be traveled becomes shortened.
- Temperature range. When removed or during charging, Temperature range should be between 40° to 110°F (4 to 43°C).
- Storage temperature. Storing the battery in excessively high or low temperature will speed up its degradation and the capacity will rapidly decrease.
- Excessive temperatures. Using the AMP in excessive temperatures will cause the battery to deteriorate and speed up its capacity to rapidly decrease.
- Never disassemble the battery. If the battery is not working, contact your Method Mobility Supplier for replacement.

#### **WARNING**

Do not submerge the battery in water. A battery that has been exposed to liquids which can cause internal corrosion or damage to the cells or to the battery management system which can present the possibility of fire during recharging.

#### **WARNING**

Do not touch the leads of the battery to anything other than the connector to the AMP base. Shorting the power leads can result in a fire or battery damage.

- Properly dispose of battery when no longer useable and never dispose of a battery in a fire. Improper disposal of battery can result in environmental damage.

### 4.4 Charging Your Amp Battery (LiFe P04)

Charge the battery in an environment with a temperature of 40° to 110°F (4 to 43°C). The battery temperature increases during charging. If the temperature rises above 158°F (70°C) the charger will turn off to protect the battery. Be sure to leave sufficient space around the charger when charging to avoid overheating. Charging should be performed in a fire-safe area, away from children or pets. Never charge battery unattended, or where objects such as carpet, furniture, wood or vinyl floors, curtains or other flammable objects come in contact with charger or battery.

#### **WARNING**

Do not expose battery to temperatures above 212°F (100°C).

#### **WARNING**

Only use AMP specified charger provided with your AMP product. Check with your Method Mobility Authorized Supplier when it becomes necessary to change out a battery and/or charger to purchase the same kind of battery or charger that was originally supplied with your AMP.

#### **WARNING**

Always check your battery for any damage to the case or if swollen or bulging, discontinue use and contact your Method Mobility supplier.

#### **WARNING**

If the battery becomes hot, smokes, swells or gives off an odor during charge, terminate charging and contact your



authorized Method Mobility supplier. Note- the charger itself may get quite warm to the touch when charging a deeply discharged battery.

- When charging your docked AMP Power Module be sure to first power off the power module (Figure L). The lights will turn off when powered off.
- Connect the charger to the Front of the Joystick (Figure I).
- Charging is complete when all charging LEDs are lit (Figure L), approximately 6 hours. (Also see Section 4.5). Disconnect the charger (Figure I); your AMP is now ready to use again. When completed disconnect the plug to the joystick and power your Amp back on. (Figure L)
- Charging your AMP Power Module when undocked. Be sure to turn the power off at the Joystick (Figure L). Follow instructions to undock wheelchair from the base. Disconnect the joystick cable (Figure J), lift the plug off the base (Figure K).
  - To charge the battery independently, lift the battery and controller shroud on the AMP Power Module (Figure M).
  - Disconnect the Battery plug (Figure N) and connect to charger plug (Figure O).
  - The charger will light Green (Figure Q) when plugged in. Once connected to the battery it will light Red (Figure P) until fully charged and then turn back to green.
  - After completing charge, unplug the charger plug and reattach the battery to the controller plug (Figure N).
  - The battery charge time is determined to be 6.5 hours. Make sure to only use the charger provided with your AMP.

## **WARNING**

Make sure the battery is sufficiently charged before use. Batteries used without sufficient charge can cause user to be stranded.

- \* Do not leave the battery unattended while charging. Doing so could cause damage to an unprotected surface.



**Figure I:** Joystick charger plug.



**Figure J:** Joystick connection.



**Figure K:** Joystick disconnected.



**Figure L:** Power on.



**Figure M:** Lift shroud.



**Figure N:** Battery disconnected.

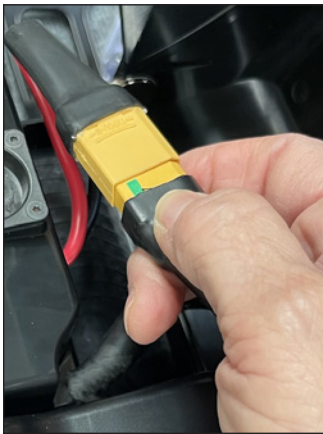

**Figure O:** Battery connected.



**Figure P:** Battery connected to charger.



**Figure Q:** Charger plugged in. Battery fully charged.

#### 4.5 Battery Storage

When storing your AMP be sure to have power off (Figure R). When you will not be using your AMP for several days or more, disconnect the battery (Figure S) or remove it from the power module and keep it in a cool place.

Batteries may be safely discharged at temperatures between 4°F and 140°F (-20°C and 60°C). Note this is the safe battery temperature rather than ambient temperature. Heavy use (frequent flashing) will cause the battery to develop internal heat beyond the ambient temperature. Note that battery capacity is lower at cold temperatures.

Batteries should be stored at temperatures between 40°F and 110°F (4°C and 43°C) for maximum life and safety. Higher storage temperatures increase the self-discharge rate from the nominal 1-2% per month to as high as 35% per month and can reduce battery life and increase the possibility of catastrophic failure with long term high temperature storage. Never store batteries at temperatures higher than 160°F (71°C) as this can potentially result in self-combustion.

Batteries may be stored at 100% charge if used frequently. However, for maximum life, batteries infrequently used should be stored at 40% to 70% charge. An easy way to bring a discharged battery into the proper long-term storage charge is to charge for about 60 minutes with the supplied charger.

Do not store the battery lower than 30-50% of charge at room temperature.

## **WARNING**

Only store the battery at acceptable storage temperature of -4°F to 122°F (-20°C to 50°C). Storage outside recommended range can cause a chemical reaction to the battery cells that can cause permanent damage and the possibility of fire or explosion during charging.



**Figure R:** Power off.



**Figure S:** Disconnect battery.

### 4.6 Charger Indicator Lights

- Green LED: Indicates fully charged. (Figure Q)
- Red LED: Indicates charging (Figure P)

### 4.7 Battery Levels and Safety

## **WARNING**

To check battery charge level see the indicator LED lights on the joystick. (Figure T). Always be aware of your battery charge level before leaving a safe place. Do not drive use the AMP when the batteries are nearly discharged. Failure to follow this warning may leave you unassisted without power.



**Figure T:** Power on.

#### 4.8 Checking Battery and Charger

The battery indicator LED lights will tell you when your battery is fully charged or discharged. (Figure U)

- Battery LED light indicator shows Green/Yellow/Red, the product is fully charged.
- Battery LED light indicator shows Yellow/Red, batteries will need to be charged as soon as possible.
- Battery LED light indicator shows Red, charge batteries immediately.



**Figure U:**

**Green/Yellow/Red:** Fully Charged

**Yellow/Red:** Batteries Need to Be Charged As Soon As Possible

**Red:** Charge Batteries Immediately

### **WARNING**

Do not exceed the maximum charging current of 6 Arms. Always use an off-board AMP charger fitted with a unique fitting for the AMP Power Module plug provided by Method Mobility, Inc. Failure to observe these conditions could result in poor contact resistance in the charger connector resulting in overheating of the charger plugs. This presents a potential burn hazard for the user. Method Mobility accepts no liability for losses of any kind arising from failure to comply with this condition.

### **WARNING**

Ensure that the charger plug pins are of the correct polarity with that shown on the specific control system's data sheet. Failure to observe this condition could result in a burn hazard or fire hazard. Method Mobility accepts no liability for losses of any kind arising from failure to comply with this condition.

## **WARNING**

Do not disconnect batteries or open circuit the circuit breaker while charging is in progress. Failure to observe this condition could result in a burns hazard or fire hazard. Method Mobility accepts no liability for losses of any kind arising from failure to comply with this condition.

## **WARNING**

The product can come to a sudden, complete stop at any time during operation. If this happens, be sure to power off/on and check all connections. If it continues, DO NOT USE and contact your Authorized Method Mobility Supplier for service.

## **WARNING**

Only use the battery charger (Figure V) that has been supplied with your AMP. The use of incorrect battery or chargers could damage the batteries, AMP, control system or charger itself; it may result in parts overheating creating the potential for burns or even fire. Method Mobility accepts no liability for losses of any kind if the charger is incompatible with the control system or any other part of the powerchair system.



**Figure V:** Battery charger.

### 4.9 Battery Wiring Diagram

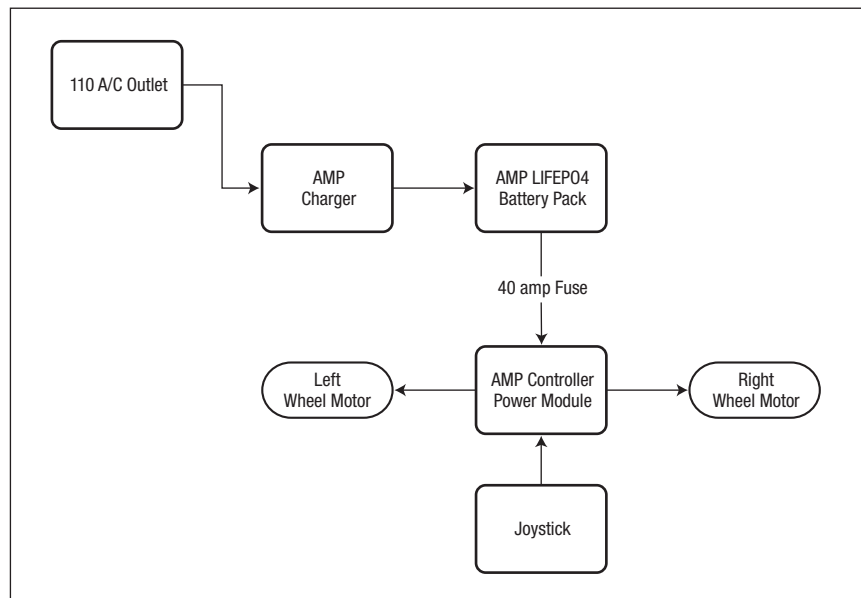

#### 4.10 Safe Disposal of Lithium-Ion Phosphate Batteries

### **WARNING**

Lithium Iron Phosphate batteries contain elements that may pose health risks to individuals if they are allowed to leach into the ground water supply. In some countries, it may be illegal to dispose of these batteries in standard household waste. Fortunately, many recycling facilities exist that process lithium-ion phosphate batteries, in part due to the value of the materials contained within the individual cells. In the United States and Canada, a large network of over 30,000 battery drop-off locations may be found at [www.call2recycle.org](http://www.call2recycle.org).

To render the battery safe, apply tape over any exposed connectors to prevent the accidental shorting of the positive and negative terminals of the battery during transport. Place each battery into its own plastic bag, seal the bag, and deposit the battery into the recycling container. **NEVER** dispose of the battery in a fire or incinerator, as the battery may catch fire and explode.

## SECTION 5 - MAINTENANCE, USE INFORMATION AND WARNINGS

### **WARNING**

The AMP user and/or caregiver are responsible for making sure that it has been set up and adjusted by a trained service professional under the advice of a healthcare professional. It may require periodic safety and function checks or certain in-use adjustments that can be performed by the user, caregiver, or authorized supplier if desired. ALWAYS use parts and/or accessories that have been recommended or approved by Method Mobility when servicing this unit.

#### 5.1 Introduction

- Proper maintenance will improve performance and extend the useful life of this device.
- Clean your AMP regularly. This will help you find loose or worn parts and make your wheelchair easier to use. You will use water and clean rags or towels.
- If you discover loose, worn, bent or damaged parts repair or replace them before using unit.
- Have all major maintenance and repair work done by your Authorized Method Mobility Supplier.
- Inspect and maintain this unit as recommended in the safety checklist (Section 5.3).
- If you detect a problem have service and repair work done at your Authorized Method Mobility Supplier before use. Use only parts that meet Method Mobility specifications.
- At least once a year, have a complete inspection, safety check and service of your AMP made by an Authorized Method Mobility Supplier.

#### 5.2 Maintenance And Cleaning

Clean weekly with a slightly damp (NOT wet) cloth. Wipe off or blow away any dust or dirt on moving parts.

#### 5.3 Important Safety Checklist

ALWAYS follow this checklist to keep your AMP in safe working condition. DO NOT use your AMP if it is not in safe working order. Contact your Authorized Method Mobility Supplier when you see a problem you need help with. Make sure you also follow safety checklists in your wheelchair user manual.

Safety Check	Daily	Weekly	Monthly	Yearly
Look at AMP Power Module to check for worn, loose or cracked parts.	X		X	
If AMP behaves Abnormally or Erratically, STOP and DO NOT OPERATE the device.	X			
Check tires for wear and correct amount of air inflation.		X		
Make sure wheelchair rolls smoothly with AMP docked in place.	X			
Check the adjustment of the Anti-tip tubes so your front casters are not greater than 2" from ground.	X			
Check for loose hardware on AMP; tighten to AMP specifications.			X	
Check battery for any wear or damage.	X			X
Have a complete inspection and service by an Authorized Method Mobility Supplier.				X

## 5.4 Troubleshooting

Main Fuse: A 40 amp fuse is located under the controller cover shroud. If the fuse has blown, disconnect the battery and replace the fuse with a 40 amp blade fuse.

Potential Malfunctions and possible solutions:

Potential Malfunction	Possible Solution
AMP will not power on/start	<p>Check battery connection.</p> <p>Check Battery to ensure is charged.</p> <p>Verify power is turned on.</p> <p>Check to ensure wheel motor parking brakes are drive position.</p>
Wheelchair will not dock and lock in	<p>Check alignment of wheels to AMP wheel docks.</p> <p>Check for obstruction in the lock lever.</p> <p>Check to ensure wheelchair manual brakes are released.</p>
Wheelchair will not undock	<p>Readjust wheelchair and pull up on egress leve.</p> <p>Check wheelchair tire pressure.</p> <p>Check to ensure wheelchair manual brakes are released.</p>
Joystick battery indicator is flashing	<p>See list in 5.7.6, Self Help Actions.</p> <p>The batteries need may need charging, see Section 4.8.</p> <p>Check the connections to the motors.</p> <p>Make sure that the joystick is in the center position before switching on the controller.</p> <p>Make sure that the joystick module cable is securely connected, see Section 5.5.</p> <p>Make sure that all connections are secure.</p> <p>Check the parking brakes are in the drive positions.</p> <p>Check the battery connections.</p>
Battery indicator low	<p>Charge battery, see Section 4.8.</p>
AMP is driving too slowly	<p>Check speed setting on joystick controller.</p> <p>Check battery charge level.</p> <p>Check to ensure wheelchair rear drive wheels are off the ground.</p>
Malfunction of any type continues	<p>Contact an authorized AMP supplier for repair.</p>
Speed Profile lights rippling up and down	<p>Joystick locked, see Section 5.7, to unlock the joystick.</p> <p>Joystick was engaged when turning on. Turn off and on again without the joystick engaged.</p>



## 5.5 Use and Set Up

### **WARNING**

The AMP user and/or caregiver are responsible for making sure that it has been set up and adjusted by a trained service professional under the advice of a healthcare professional. Service and/or adjustments should only be done by an authorized professional. ALWAYS use parts and/or accessories that have been recommended and approved by Method Mobility.

- Initial Set-Up/Operating
  - Docking and undocking wheelchair to the AMP Power Module.
    - Make sure the joystick cable is free and clear from wheels and base to avoid damage.
    - Align rear manual wheelchair wheels to the AMP (Figure W). Keep hands and fingers clear of any components to avoid any potential pinch points. Back wheelchair onto the unit until the AMP clicks (sound) to lock in (dock) (Figure X). Manual wheelchair wheels will not move when docked properly.
    - Always lock manual wheels with wheelchair wheel locks when using the joystick or attendant control AMP. (Figure Y) By locking the wheel locks on the wheelchair this will eliminate rearward tipping of the wheelchair.
    - When not using wheel locks, be sure to turn anti-tips up and make sure they are adjusted so the front casters do not raise greater than 2" (two inches) off ground. The wheelchair anti-tips will contact the anti-tip bumper which restricts the wheelchair's rearward tip.
    - Next, plug the joystick into the AMP power module (Figure J). After it is plugged in turn joystick on. (Figure Z)
    - Wheelchair is maneuvered with joystick control. When joystick is plugged in, the handrims do not maneuver wheelchair. Before riding be sure to be trained by a healthcare advisor on the safe use of the product. Never try a new maneuver without training or advice from a healthcare professional.
    - To unlock (remove) the wheelchair from the AMP power module. Turn off the power (Figure L) and disengage the wheel locks. Next, release the handle in the rear of the unit and roll forward off the AMP power module.



**Figure W:** Undocked.  
Align to wheel catches.



**Figure X:** Docked.



**Figure Y.**

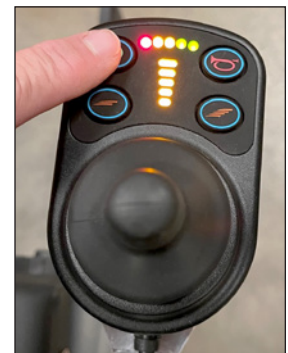

**Figure Z.**

## 5.6 Joystick Set-Up and Use

- Joystick information and warnings are marked as follows for their relevance to particular stakeholders:
  - User (US) – User or Caregiver
  - Healthcare Professional (HP) – the person assessing User needs (may also be a Trained Service Professional).
  - Trained Service Professional (TSP) – the person fitting system to the wheelchair and / or programming to suit the User (may also be a Healthcare Professional).

## 5.7 General Joystick Information

- Handling
  - Avoid knocking your control system and especially the joystick. Be careful not to strike obstacles with the control system or joystick when you drive. Never drop the control system.
  - When transporting your wheelchair, make sure that the control system is well protected. Avoid damage to cables.
- Operating Conditions
  - Your control system uses industrial-grade components throughout, ensuring reliable operation in a wide range of conditions. However, you will improve the reliability of the control system if you keep exposure to extreme conditions to a minimum.
  - Do not expose your control system or its components to damp for prolonged periods. If the control system becomes contaminated with food or drink clean it off as soon as possible.
- Cleaning
  - Clean the control system and the joystick with a cloth dampened with diluted detergent. Be careful when cleaning the joystick. Never use abrasive or spirit-based cleaners.
- On/Off Button and Battery Discharge Indicator (BDI)
  - The On/Off button applies power to the control system electronics, which in turn supply power to the wheelchair's motors. Do not use the On/Off button to stop the wheelchair unless there is an emergency. If you do, you may shorten the life of the wheelchair drive components.
  - The Battery Indicator shows you that the wheelchair is switched on. It also indicates the operating status of the wheelchair.
  - When the Battery Discharge Indicator has a steady LED light, all is well.
  - When the first LED flashes slowly, the system is functioning correctly, but should be charged as soon as possible.
  - When the LED step up, the batteries are being charged. You will not be able to drive with the AMP Power Module until the charger is disconnected and you have switched the system off and on again.
  - When the Battery Discharge Indicator flashes rapidly (even when joystick is not engaged) the system is prevented from moving the wheelchair. This will indicate a system trip such as a problem in the unit's electrical system. Follow this procedure:
    - Switch off the control system.
    - Make sure that all connectors on the powerchair and the control system are mated securely.
    - Check the condition of the batteries.
    - If you cannot find the problem, try using the self-help guide (following section) to trouble shoot.
    - Switch on the control system again and try to drive the powerchair. If the safety circuits operate again, switch off and do not try to use the powerchair. Contact your service agent.
- Self-Help Guide
  - If a system trip occurs, you can find out what has happened by counting the number of flashes on the Joystick Module Battery Discharge Indicator.
  - Below is a list of self-help actions. Try to use this list before you contact your service agent. Go to the number in the list which matches the number of flashes on the Battery Discharge Indicator (BDI) and follow the instructions.
  - If the problem persists after you have made the checks described, contact your authorized service agent.
- Self-Help Actions
  - **1 Flash:** The batteries need charging or there is a bad connection to the batteries. Check the connections to the batteries. If the connections are good, try charging the batteries.
  - **2 Flashes:** The left-hand motor or encoder has a bad connection. Check the connections to the left-hand motor and encoder.
  - **3 Flashes:** The left-hand motor wiring is faulty, or a stall condition has been detected.

- **4 Flashes:** The right-hand motor or encoder has a bad connection. Check the connections to the right-hand motor and encoder.
- **5 Flashes:** The right-hand motor wiring is faulty or a stall condition has been detected.
- **7 Flashes:** A joystick fault is indicated. Make sure that the joystick is in the center position before switching on the controller.
- **7 Flashes+ 'S':** A communication fault is indicated. Make sure that the joystick module cable is securely connected and not damaged. (S = Flashing Speed Indicator LEDs.)
- **8 Flashes:** A possible controller fault is indicated. Make sure that all connections are secure.
- **9 Flashes:** The parking brakes have a bad connection. Check the parking brake and motor connections. Make sure the controller connections are secure.
- **10 Flashes:** An excessive voltage has been applied to the controller. This is usually caused by a poor battery connection. Check the battery connections.
- Locking / Unlocking the AMP Power Module

The control system can be locked to prevent unauthorized use. The locking method is via a sequence of key presses and joystick movements, as detailed below.

- To lock the AMP Power Module:
  - While the control system is switched on, depress and hold the On/Off button.
  - After 1 second the control system will beep. Now release the On/Off button.
  - Deflect the joystick forwards until the control system beeps.
  - Deflect the joystick in reverse until the control system beeps.
  - Release the joystick, there will be a long beep.
  - The AMP Power Module is now locked.
- To unlock the AMP Power Module:
  - Use the On/Off button to switch the control system on. The maximum speed / profile indicator will be rippling up and down.
  - Deflect the joystick forwards until the control system beeps.
  - Deflect the joystick in reverse until the control system beeps.
  - Release the joystick, there will be a long beep.
  - The AMP Power Module is now unlocked.

## 5.8 Joystick Use

The primary function of the joystick is to control the speed and direction of the AMP Power Module. The further you push the joystick from the center (starting) position the faster the AMP Power Module will move. When you release the joystick, the brakes are automatically applied.

- Maximum Speed / Profile Indicator
  - This is a gauge which shows the maximum speed setting for the AMP Power Module or, if the control system is programmed for drive profile operation, the selected drive profile.
  - This gauge also indicates if the speed of the AMP Power Module is being limited or if the control system is locked. The number of LEDs illuminated shows the selected drive profile. For example, if drive profile 4 is selected, then the fourth vertical LED will be illuminated.
- Maximum Speed Indicator
  - This is a gauge that shows the maximum speed setting of the AMP Power Module. There are five speed settings – step 1 is the lowest speed and step 5 is the highest speed.

- Speed / Profile Decrease Button
  - This button decreases the maximum speed setting or, if the control system is programmed for drive profile operation, selects a lower drive profile.
- Speed / Profile Increase Button
  - This button increases the maximum speed setting or, if the control system is programmed for drive profile operation, selects a higher drive profile.
- Horn Button
  - The horn will sound while this button is depressed.
- Charger And Programmer Socket
  - This socket should only be used for programming and charging the AMP Power Module.
  - This socket should not be used as a power supply for any other electrical device. Connection of other electrical devices may damage the control system or affect the EMC performance of the wheelchair.

**⚠ WARNING**  
(US, HP, TSP)

The control system warranty will be voided if any device other than a PG Drives Technology Programmer, or the battery charger supplied with the AMP power module, is connected into this socket.

### 5.9 Getting Ready to Drive

- Operate the On/Off switch. The Battery Discharge Indicator (BDI) will blink then remain on after a second.
- Check that the maximum speed control is set to a level which suits you.
- Push the joystick to control the speed and direction of the AMP Power Module.

**NOTE (US):** If you push the joystick before or just after you switch the control system on, the Battery Discharge Indicator (BDI) will ripple up and down and the wheelchair will not be allowed to move. You must release the joystick to resume normal operation. If you do not release the joystick within five seconds, the wheelchair will not be able to move, even if you release the joystick and push it again. The Battery Discharge Indicator (BDI) will then flash rapidly. You can reset this condition by switching the control system off and on again.

### 5.10 Driving – General

- Make sure that the control system is mounted and that the joystick position for the user or attendant is correct.
- The hand or limb you use to operate the joystick should be supported, for example by the wheelchair arm pad.
- Do not use the joystick as the sole support for your hand or limb – AMP Power Module movements and bumps could upset your control.
- Swing away joystick can either be retracted or forward in use (Figures AA and BB).



**Figure AA:** Joystick forward.



**Figure BB:** Joystick retracted.

## 5.11 Driving Technique

- The control system interprets your joystick movements and produces appropriate movements of your wheelchair. You will need little concentration to control the wheelchair, which is especially useful if you are inexperienced.
- One popular technique is to simply point the joystick in the direction you want to go. The wheelchair will “home-in” on the direction you push the joystick.
- The further you push the joystick away from the rest position, the faster the chair will go.
- Releasing the joystick will stop the wheelchair.
- The intelligent speed control system minimizes the effects of slopes and different types of terrain.

### **WARNING**

(HP, TSP)

The AMP Power user must be capable of driving safely. Method Mobility accepts no liability for losses of any kind arising from failure to comply with this condition.

### **WARNING**

(US)

In the event of the wheelchair moving in an unexpected way RELEASE THE JOYSTICK. This action will stop the wheelchair under any circumstances.

## 5.12 Hazards

- Do not drive the wheelchair:
  - Beyond restrictions indicated in your wheelchair user manual, for example maximum inclines, curb height etc.
  - In places or on surfaces where a loss of wheel grip could be hazardous, for example on wet grassy slopes.
  - If you know that the control system or other crucial components require repair.

### **WARNING**

(US, HP, TSP)

Although the control system is designed to be extremely reliable and each unit is rigorously tested during manufacture, the possibility of a system malfunction always exists (however small the probability). Under some conditions of system malfunction the control system must (for safety reasons) stop the wheelchair instantaneously. If there is any possibility of the user falling out of the wheelchair as a result of a sudden braking action, it is imperative that a restraining device such as a seat belt is supplied with the wheelchair and that it is in use at all times when the wheelchair is in motion. Method Mobility accepts no liability for losses of any kind arising from the unexpected stopping of the wheelchair, or from the improper use of the wheelchair or control system.

### **WARNING**

(US)

Do not operate the control system if the wheelchair behaves erratically, or shows abnormal signs of heating, sparks or smoke. Turn the control system off at once and consult your service agent. Method Mobility accepts no liability for losses of any kind arising from failure to comply with this condition

### **WARNING**

(US)

Electronic equipment can be affected by Electro Magnetic Interference (EMI). Such interference may be generated by radio stations, TV stations, other radio transmitters and cellular phones. If the wheelchair exhibits erratic behavior due to EMI, turn the control system off immediately and consult your Authorized Method Mobility Supplier. Method Mobility accepts no liability for losses of any kind arising from failure to comply with this condition.

## **WARNING**

It is the responsibility of the wheelchair manufacturer to ensure that the wheelchair complies with appropriate National and International E.M.C legislation. Method Mobility accepts no liability for losses of any kind arising from failure to comply with this condition.

## **WARNING**

(US, HP, TSP)

The wheelchair user must comply with all wheelchair safety warnings. Method Mobility accepts no liability for losses of any kind arising from failure to comply with this condition.

### **5.13 Joystick Knobs**

- The knob fitted to your joystick is suitable for most applications.
- If you would prefer another type, there is a range of alternatives available. Please contact your wheelchair distributor or manufacturer for advice.
- Do not replace the joystick knob with any unauthorized item – it may cause hazardous operation.

## **WARNING**

(US, HP, TSP)

Do not replace the joystick knob with any unauthorized item. It may cause hazardous operation. Method Mobility accepts no liability for losses of any kind arising from failure to comply with this condition.

### **5.14 Storage**

- When AMP is not in use be sure the unit is turned off and stored in a cool, dry place with a temperature range between 50 to 77° F (10 to 25°C).
- Disconnect the battery when not in use for extended period of time.



**Figure CC:** Battery disconnected.

### 5.15 Freewheel Mode

Freewheel AMP Power Module when need to roll chair without power.

- To freewheel push lever at motors downward (Figure DD).



**Figure DD:** Push down motor lever.

- To engage motors reverse lever position, upward.

### **WARNING**

Do not use foot to move freewheel levers, only adjust with hands.





## SECTION 6 - AUTHORIZED METHOD MOBILITY SUPPLIER, SERVICE AND ADJUSTMENT

### 6.1 Service and Adjustment

AMP service and adjustments should only be made by Authorized Method Mobility Suppliers. They are familiar with product requirements and specifications. They also know specifications for any needed replacement parts. At least once a year, have a complete inspection, safety check and service of your AMP made by an Authorized Method Mobility Supplier.



## SECTION 7 - LIMITED LIFETIME WARRANTY

### 7.1 Warranty Details

The Method Mobility Warranty applies only to original purchaser of the AMP and may require Proof of Purchase. Registering your AMP can make it easier to check your warranty and product information ([www.methodmobility.com/registration](http://www.methodmobility.com/registration)). Page 3 of this manual has a QR code that will take you directly to the registration page. Warranty does not apply if AMP has been subject to abuse or not maintained per instructions in this user manual. Any defective parts will be replaced or repaired through an Authorized Method Mobility Supplier.

- Power module frame is warranted for the lifetime of the product to be free of any manufacturer defects or defective parts.
- Controller, charger and removeable components (joystick hardware) are warranted for ONE year from date of purchase.
- General wear items such as casters, tires, shroud, removeable parts or batteries are not warranted.
- Other exclusions of the original warranty may include any modifications made to the base without written consent by Method Mobility and/or exceeding AMP weight limit.

### 7.2 Service Record

Note your purchase date here. Also note reminders of when you had your recommended, yearly complete inspection, safety check and service of your AMP made by an Authorized Method Mobility Supplier.

AMP Purchase Date: \_\_\_\_\_

Inspection, Safety Check and Service Dates and Who Performed Them:

---

---

---

---

---

---

---

---

---

---



**Method Mobility**  
2562 N. Fordham Avenue  
Fresno, CA 93727 USA  
Telephone: (888) 88AMP88 (882-6788)  
Email: [CustomerCare@methodmobility.com](mailto:CustomerCare@methodmobility.com)